



US 20170239044A1

(19) **United States**

(12) **Patent Application Publication**  
**Johnson et al.**

(10) **Pub. No.: US 2017/0239044 A1**

(43) **Pub. Date: Aug. 24, 2017**

(54) **HEART VALVES WITH INCREASED EFFECTIVE ORIFICE AREA**

**Publication Classification**

(71) Applicant: **Edwards Lifesciences Corporation**, Irvine, CA (US)

(51) **Int. Cl.**  
*A61F 2/24* (2006.01)

(72) Inventors: **Derrick Johnson**, Orange, CA (US);  
**Van Huynh**, Anaheim, CA (US);  
**Qinggang Zeng**, Mission Viejo, CA (US)

(52) **U.S. Cl.**  
CPC ..... *A61F 2/2418* (2013.01); *A61F 2/2412* (2013.01); *A61F 2/2409* (2013.01); *A61F 2250/006* (2013.01)

(21) Appl. No.: **15/591,915**

(57) **ABSTRACT**

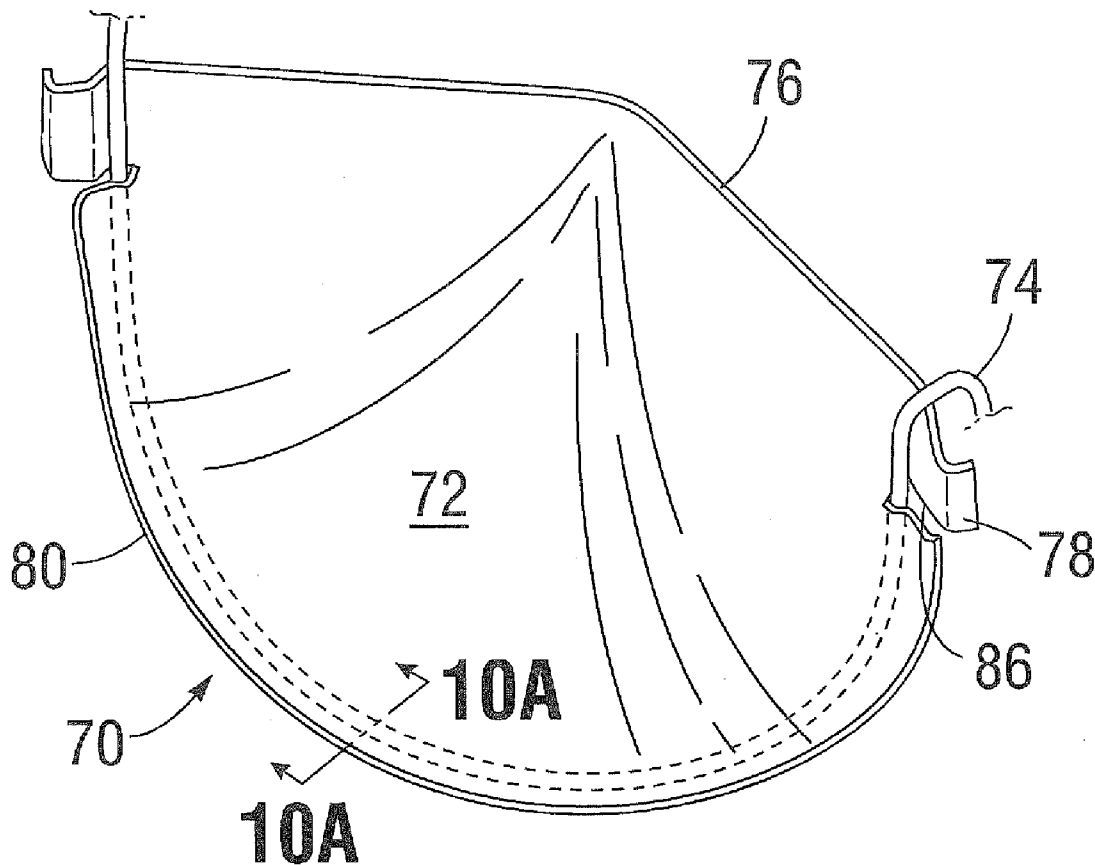
(22) Filed: **May 10, 2017**

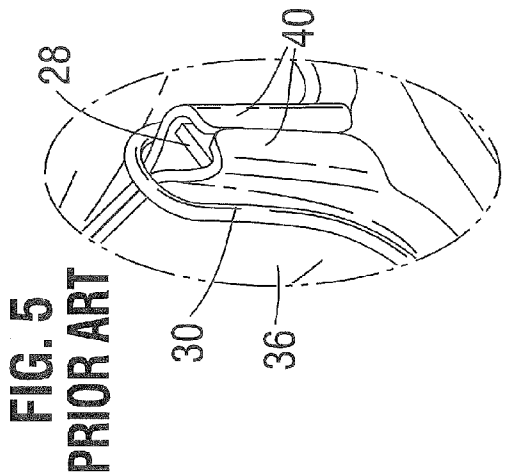
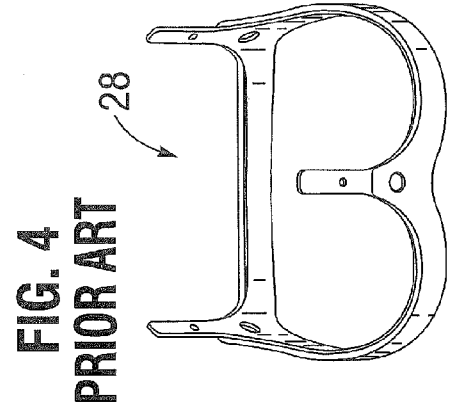
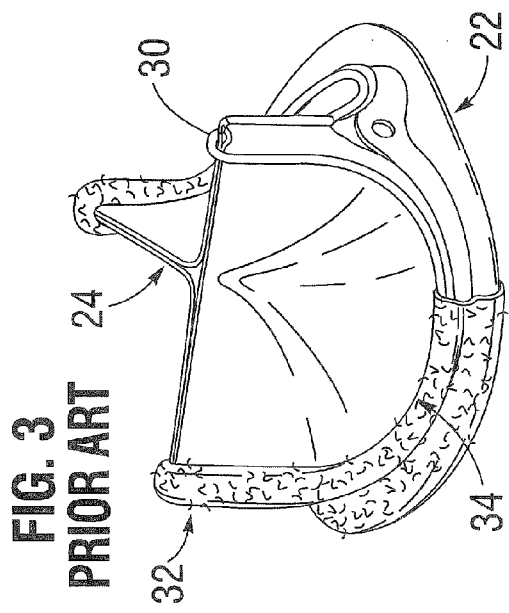
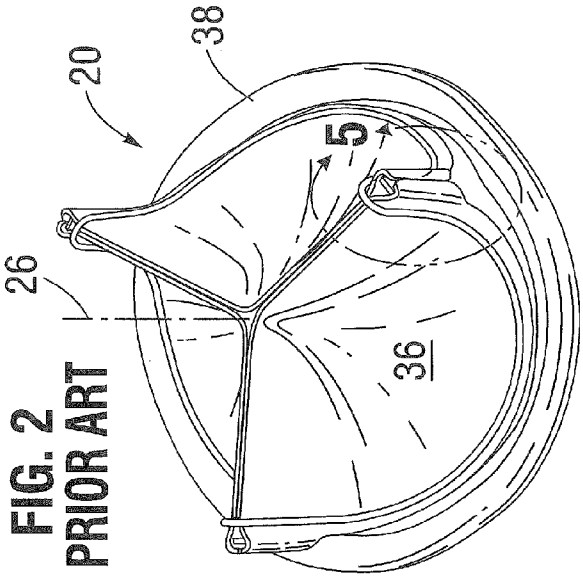
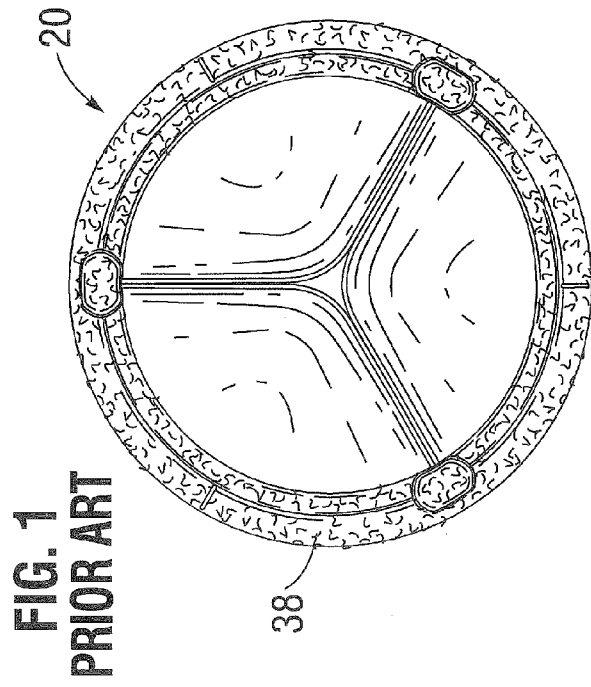
A prosthetic heart valve for implant in a human. The valve includes a wireform with undulating inflow cusps and outflow commissure posts to which flexible leaflets attach and coapt in a flow area. Each leaflet may drape over the top of the wireform in the cusp area, but have tabs that each extend underneath the wireform at the commissure posts to be secured along with a tab of an adjacent leaflet. The prosthetic heart valve may also be a dual-wire wireform, with the leaflets sandwiched therebetween. One wireform may be larger than the other, with the leaflets extending over the smaller wireform. The smaller wireform may have commissures that bend radially outward from the larger wireform to provide structure to which the leaflet tabs attach.

**Related U.S. Application Data**

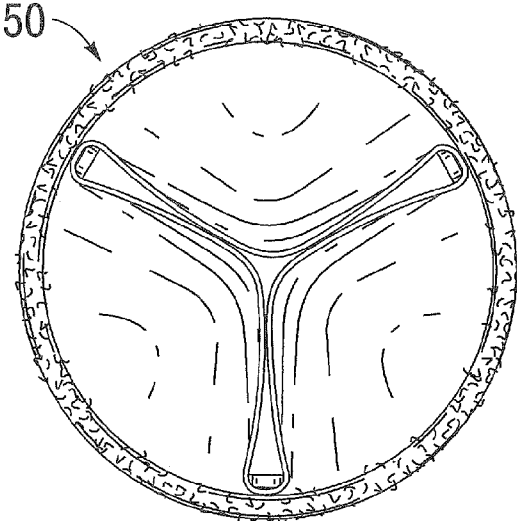
(62) Division of application No. 14/488,728, filed on Sep. 17, 2014.

(60) Provisional application No. 61/880,688, filed on Sep. 20, 2013.

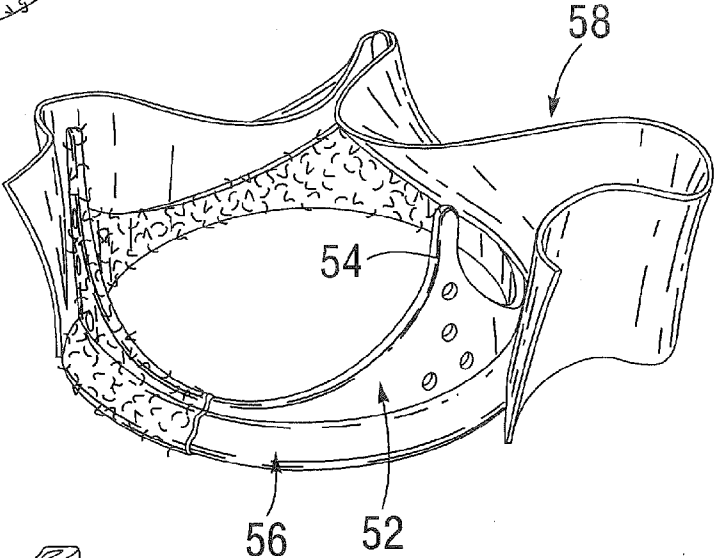




**FIG. 6**  
**PRIOR ART**



**FIG. 7**  
**PRIOR ART**



**FIG. 8**  
**PRIOR ART**

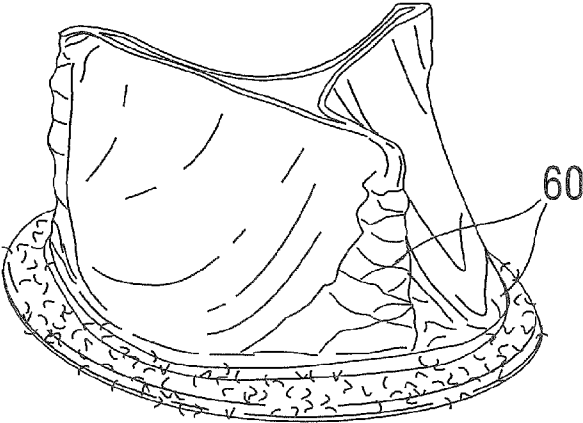


FIG. 9A

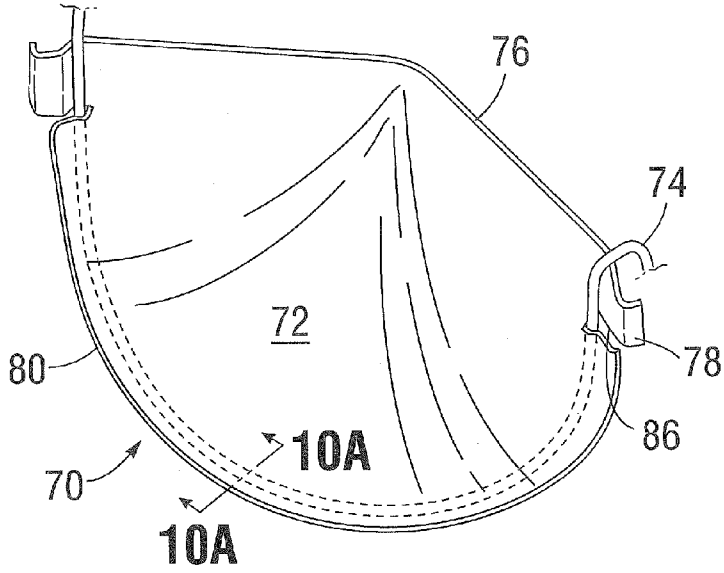


FIG. 10A

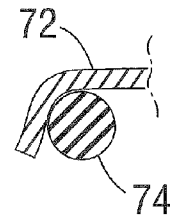


FIG. 9C

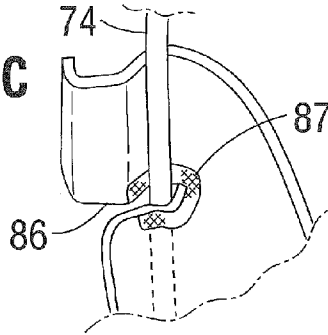


FIG. 10B

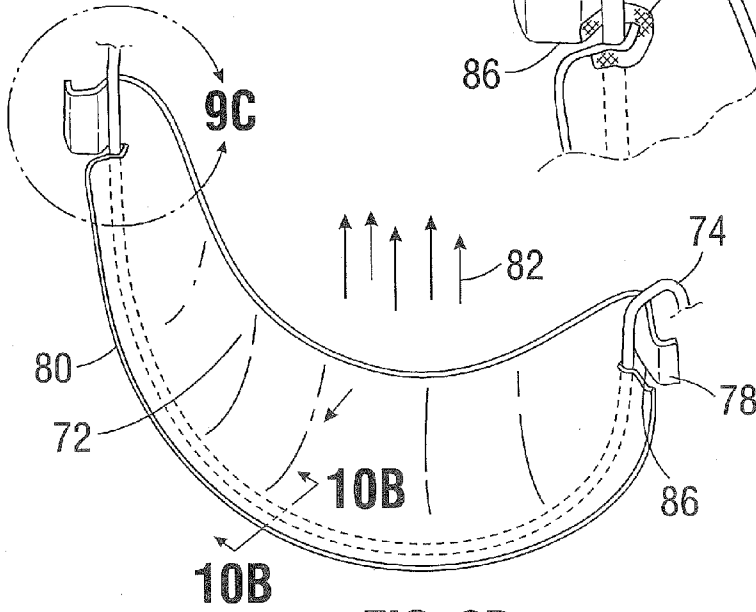
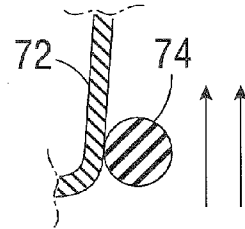


FIG. 10C

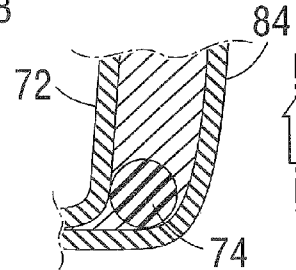
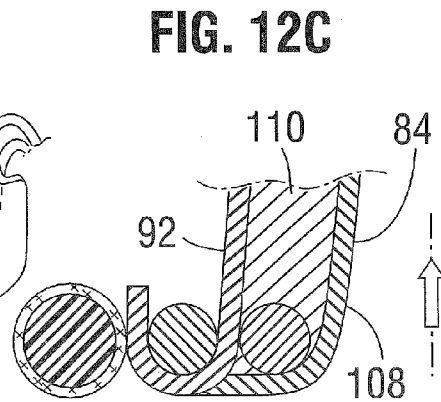
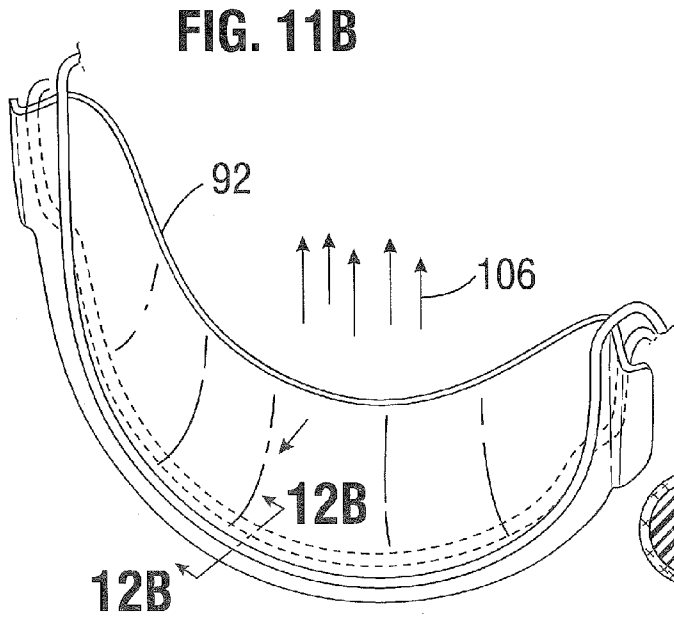
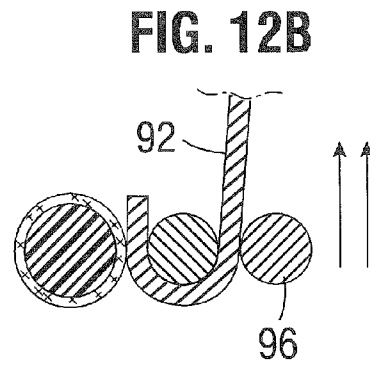
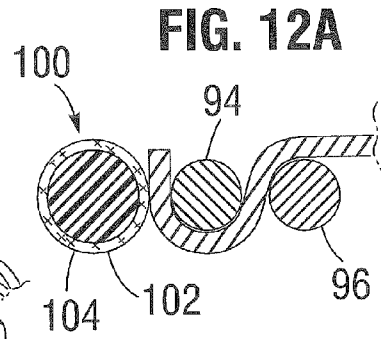
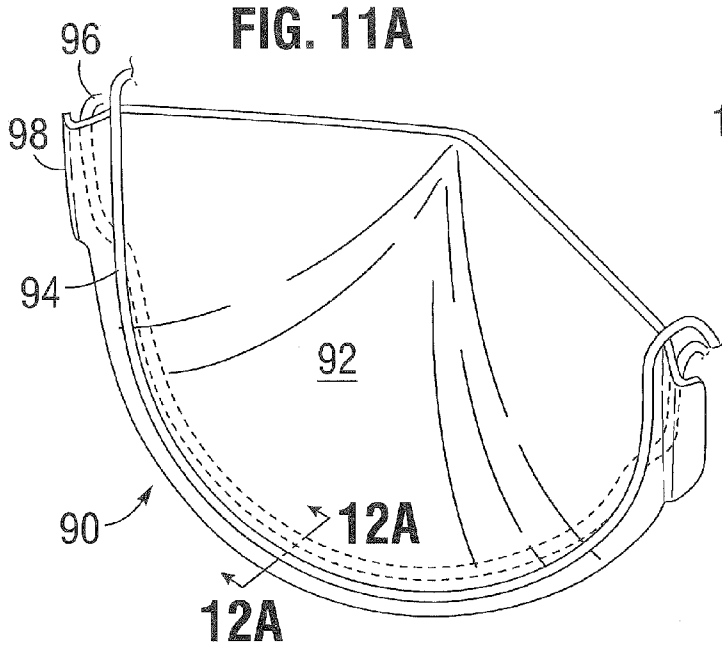
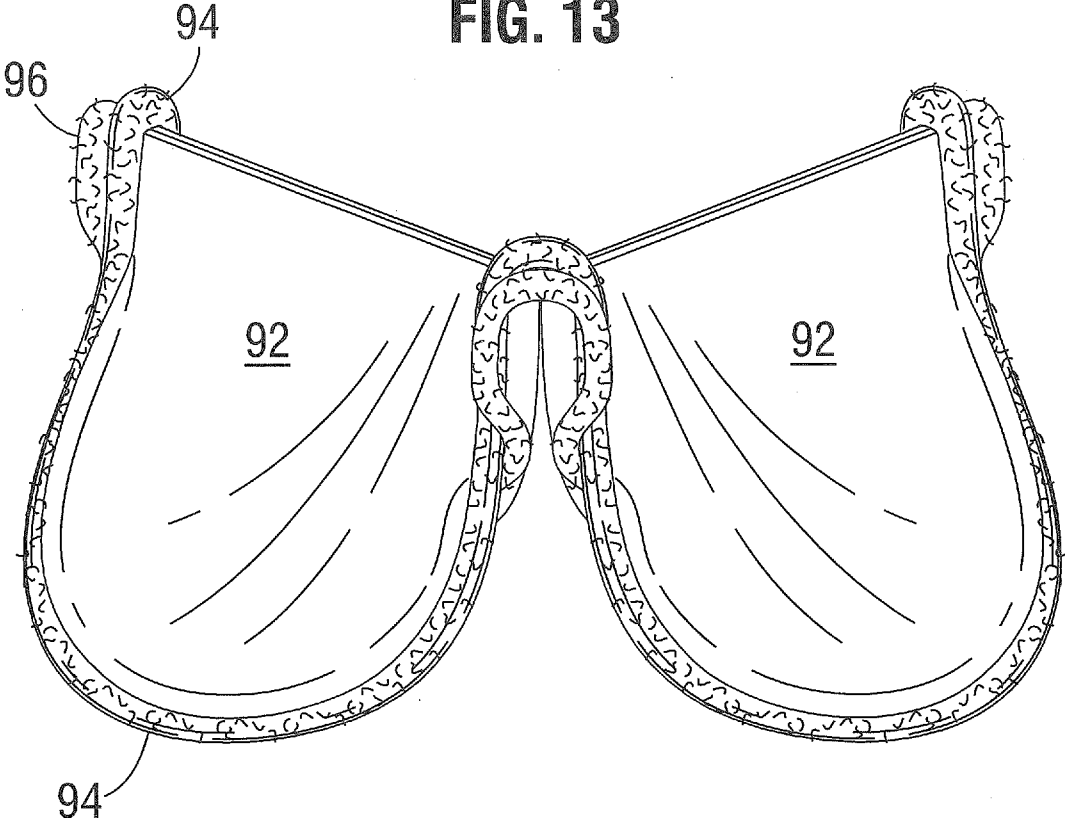
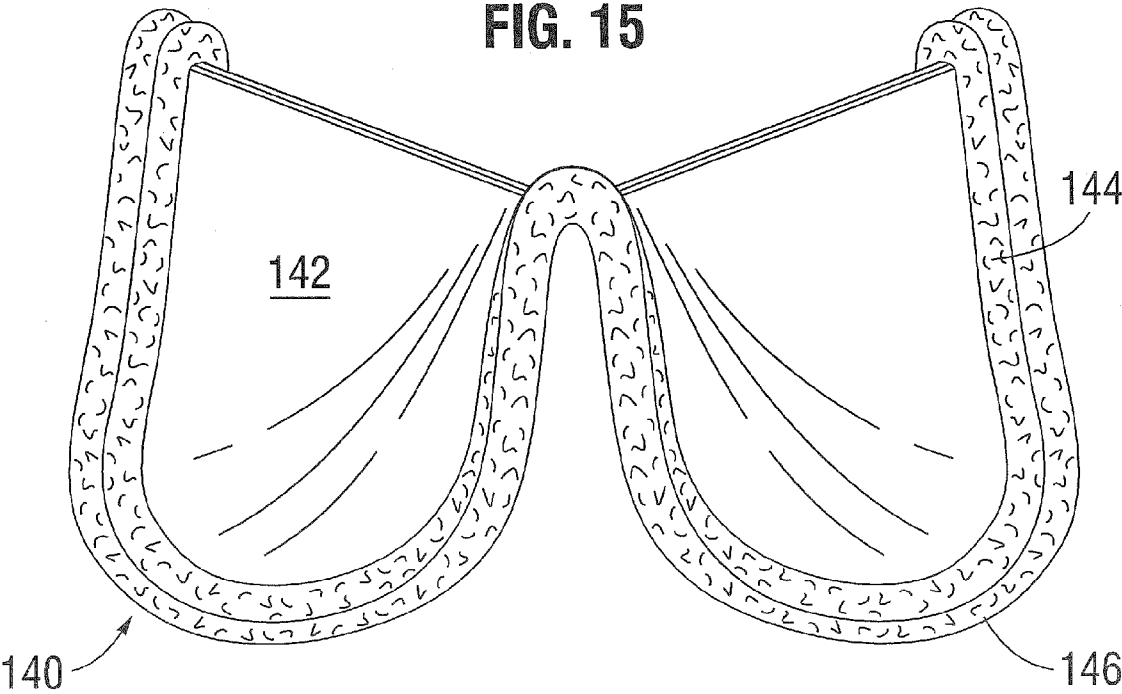
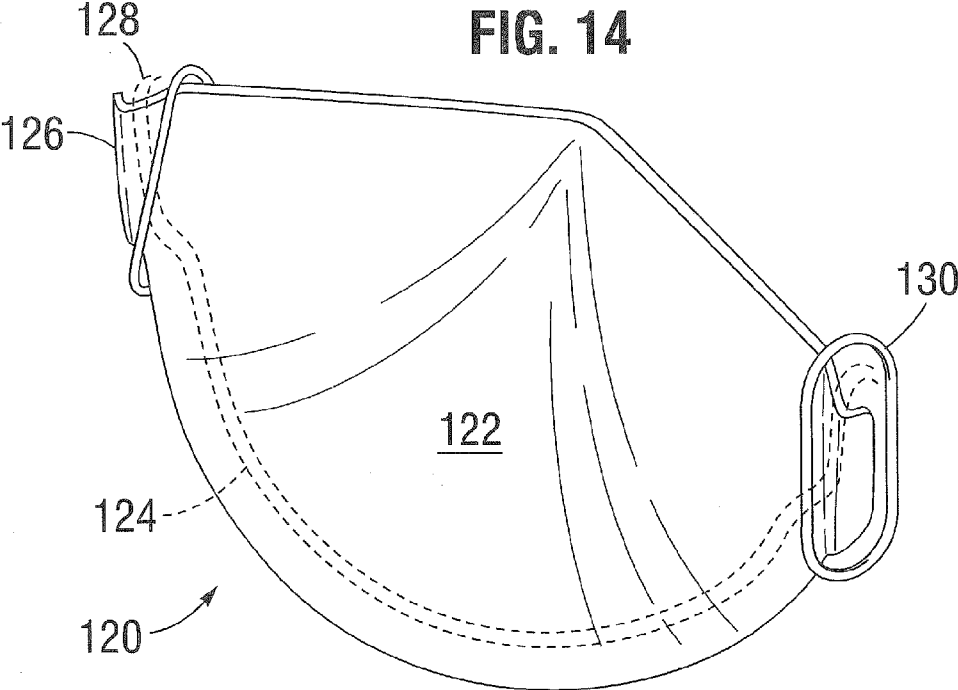


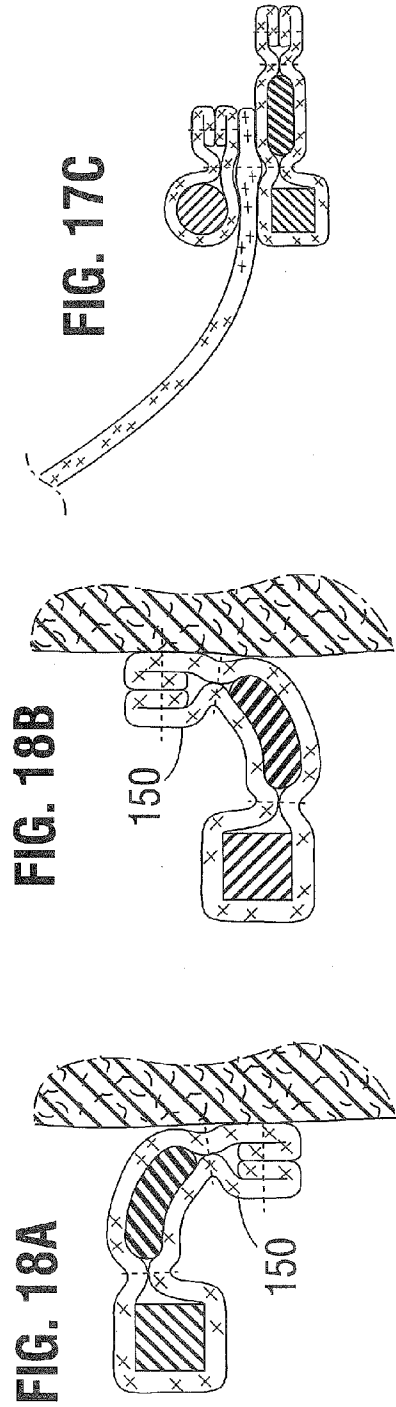
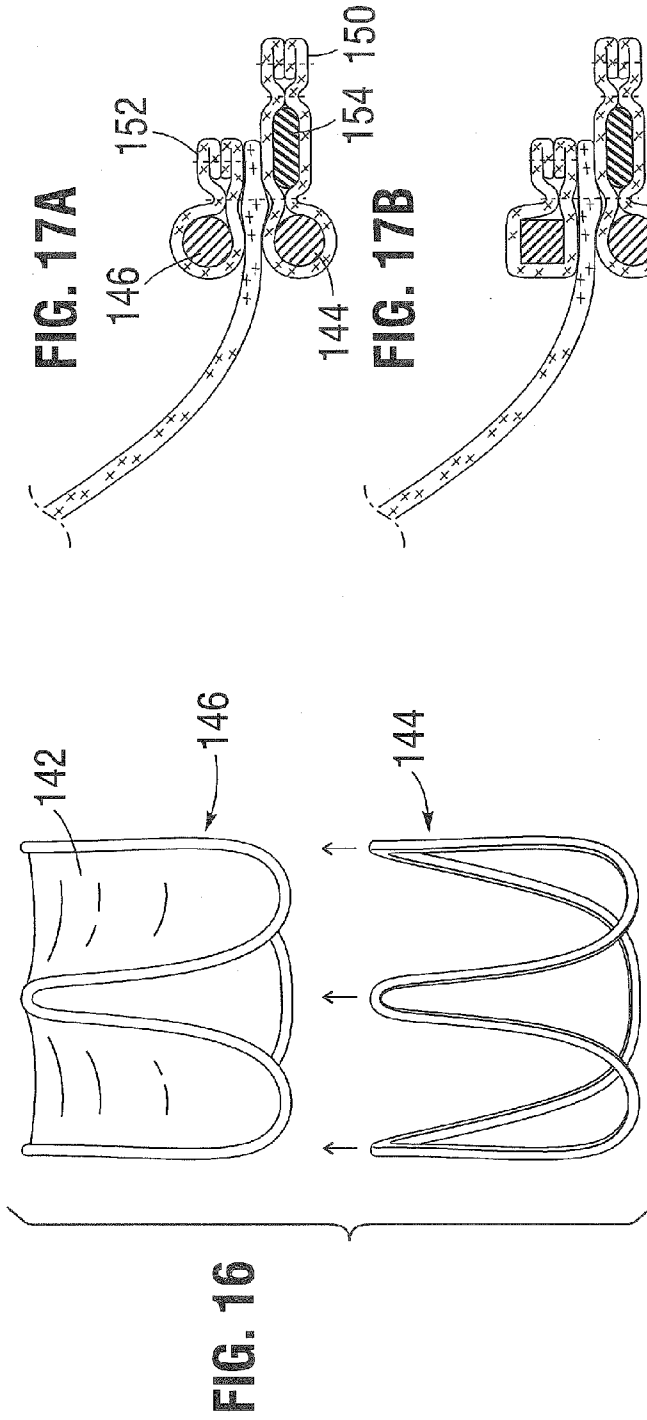
FIG. 9B



**FIG. 13**









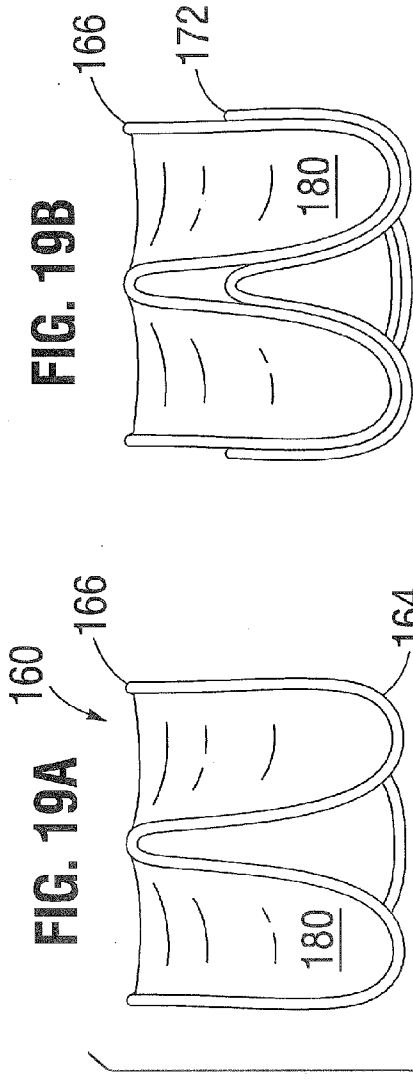


FIG. 20B

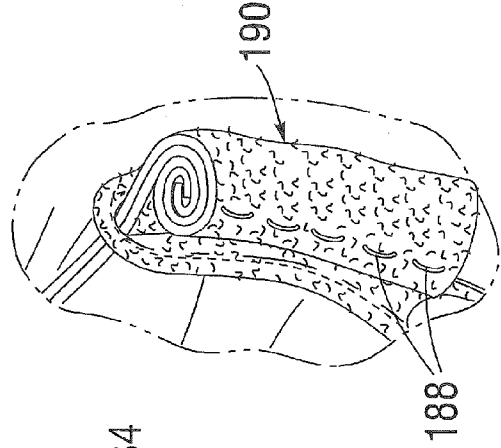
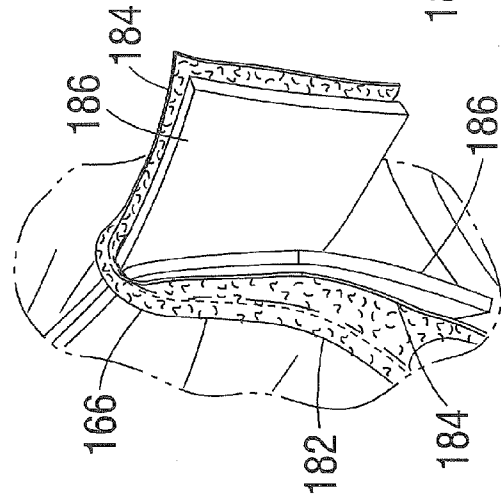


FIG. 20A



## HEART VALVES WITH INCREASED EFFECTIVE ORIFICE AREA

### CROSS REFERENCE TO RELATED APPLICATIONS

[0001] This application is a divisional of U.S. application Ser. No. 14/488,728, filed Sep. 17, 2014, which claims the benefit of U.S. application Ser. No. 61/880,688, filed Sep. 20, 2013, the entire disclosures of which are incorporated by reference.

### FIELD OF THE INVENTION

[0002] The present invention relates to a prosthetic heart valve having increased flow area for enhanced flow and, more particularly, to a flexible leaflet valve with modified stent and leaflet structure that increases the effective orifice area for a given valve size.

### BACKGROUND OF THE INVENTION

[0003] Heart valve disease continues to be a significant cause of morbidity and mortality, resulting from a number of ailments including rheumatic fever and birth defects. Currently, the primary treatment of aortic valve disease is valve replacement. Worldwide, approximately 300,000 heart valve replacement surgeries are performed annually, many involving mechanical heart valves composed of rigid, synthetic materials while the rest receive bioprosthetic heart valves which utilize biologically derived tissues for flexible fluid occluding leaflets. In general, bioprosthetic valve replacements have good hemodynamic performance and do not require the anticoagulation therapy necessary for mechanical heart valves.

[0004] Flexible leaflets used in heart valves are typically made from bioprosthetic homograft or xenograft materials. For example, the most successful bioprosthetic materials are whole porcine valves and separate leaflets made from bovine pericardium stitched together to form a tri-leaflet valve. In addition, flexible leaflets formed of polymeric, fiber-reinforced, and other synthetic materials have been proposed. The most common bioprosthetic valve construction includes three leaflets mounted around a peripheral support structure with free edges that project toward an outflow direction and meet or coapt in the middle of the flowstream.

[0005] Aortic stenosis is abnormal narrowing of the aortic valve characterized by a significantly higher than normal pressure gradient across the aortic valve. It follows that an important characteristic of a replacement aortic valve is minimal aortic pressure gradient, typically attained by increasing the effective orifice area through the valve. Solutions include placement of the prosthesis (sub-annular, intra-annular and supra-annular) in order to implant a prosthesis with the largest possible effective orifice area. Supra-annular placement (where the sewing cushion lies above the aortic annulus) is often preferred because usually a valve with a larger internal orifice diameter can be implanted. However, in patients with small aortic roots, either due to anatomy, physical stature, or severe calcification, only the smallest-sized valves (e.g., 19 mm) may be used. Sometimes an even smaller valve would be desirable, but valves smaller than 19 mm are not commercially available. Moreover, even with a supra-annular implant, the valve often does not maximize the flow orifice area.

[0006] In view of actual and perceived drawbacks associated with current bioprosthetic heart valves, a valve with an increased effective orifice area for a given valve size is desirable.

### SUMMARY OF THE INVENTION

[0007] The present application provides a low pressure gradient prosthetic heart valve for implant in a human. The valve includes a wireform with undulating inflow cusps and outflow commissure posts to which flexible leaflets attach and coapt in a flow area.

[0008] One aspect of the present application is a prosthetic heart valve comprising a first cloth-covered undulating wireform having alternating cusps and commissures around a periphery. A second cloth-covered undulating wireform has alternating cusps and commissures around a periphery, and the cusps and commissures of the two wireforms are aligned with one another. A plurality of flexible leaflets have outer edges sandwiched between the cusps of the first and second cloth-covered undulating wireforms. In one embodiment, the flexible leaflets have commissure edges sandwiched between the commissures of the first and second cloth-covered undulating wireforms. A cloth tab on one of the wireforms may encompass a small piece of silicone ribbon at least at the cusps thereof to provide a sewing ring.

[0009] The first and second wireforms may have similar sizes and shapes, with the cusps curving in an inflow direction and the commissures defining upstanding commissure posts with inverted U-shapes projecting in an outflow direction. The first wireform may be slightly smaller in radius and shorter in axial dimension than the second wireform which is positioned outward from the first wireform except at the aligned commissures where the first wireform bends outward so that its commissures are radially outside the second wireform and provide sewing anchors for commissure tabs of the flexible leaflets. The flexible leaflets preferably have tabs that are sandwiched between the first and second wireforms at the aligned commissures. In one version, the tabs of the flexible leaflets wrap around the first wireform and are attached thereto at the aligned commissures.

[0010] In another embodiment, the cusps of both wireforms curve in an inflow direction and the commissures of the second wireform define upstanding commissure posts with inverted U-shapes projecting in an outflow direction, wherein the first wireform has truncated commissures of about one half the height of the commissures of the second wireform. The flexible leaflets may have commissure tabs that extend outward through the inverted U-shaped commissures of the second cloth-covered wireform and are secured to cloth tabs extending from the cloth covering the second wireform.

[0011] In another embodiment, a prosthetic heart valve comprises a cloth-covered undulating wireform with alternating cusps and commissures, the commissures extending generally axially in an outflow direction and defining inverted U-shaped commissure posts. A plurality of flexible leaflets have outer cusp edges that extend over the top of the cusps of the wireform, and each of the leaflets has a free-edge that, when implanted, moves back and forth in and out of the flow orifice and coapts with the free edges of the other leaflets. Each leaflet also has tabs at either end of the free edge that project radially outward under the inverted

U-shaped commissure posts and are secured thereto along with a tab from an adjacent leaflet.

[0012] The outer cusp edge of each leaflet desirably interrupted by two inwardly-directed slits that each receive a portion of the wireform near the U-shaped commissures on either side of the leaflet to permit the leaflet tabs to pass under the U-shaped commissures. The inwardly-directed slits may terminate in a rounded hole to closely conform around the wireform. A reinforced strip of material may be attached around the rounded holes, or more generally around the termination of the slits.

[0013] In a further embodiment, a prosthetic heart valve comprises a cloth-covered undulating wireform with alternating cusps and commissures, the commissures extending generally axially in an outflow direction and defining inverted U-shaped commissure posts, with the commissures bent outward and then generally axially again. A plurality of flexible leaflets have outer cusp edges that extend over the top of the cusps of the wireform, and each of the leaflets has a free-edge that, when implanted, moves back and forth in and out of the flow orifice and coapts with the free edges of the other leaflets. Each leaflet having tabs at either end of the free edge that project radially outward around the outside of the inverted U-shaped commissure posts. A commissural clip extends over the top of each wireform and leaflet tab at the commissures and is sewn to the cloth-covered wireform and leaflet tabs to secure the leaflet tabs around the wireform. The commissural clips may have a closed oval shape. The cloth tab on the wireform preferably encompasses a small piece of silicone ribbon at least at the cusps thereof to provide a sewing ring.

[0014] A further understanding of the nature and advantages of the present invention are set forth in the following description and claims, particularly when considered in conjunction with the accompanying drawings in which like parts bear like reference numerals.

BRIEF DESCRIPTION OF THE DRAWINGS

[0015] Features and advantages of the present invention will become appreciated as the same become better understood with reference to the specification, claims, and appended drawings wherein:

[0016] FIG. 1 is a plan view looking from the outflow end of a flexible leaflet bioprosthetic heart valve of the prior art;

[0017] FIG. 2 is a perspective view of certain inner components of the heart valve of FIG. 1;

[0018] FIG. 3 is a partially cutaway view of the assembled heart valve of FIG. 1;

[0019] FIG. 4 is a perspective view of an inner stent assembly for the prior art heart valve of FIG. 1;

[0020] FIG. 5 is an enlarged perspective view of a commissure region of the heart valve of FIG. 1 with cloth coverings removed for clarity;

[0021] FIG. 6 is a plan view looking from the outflow end of an alternative flexible leaflet bioprosthetic heart valve of the prior art;

[0022] FIG. 7 is a partially disassembled perspective view of the heart valve of FIG. 6 showing certain internal components;

[0023] FIG. 8 is a perspective view of the assembled heart valve of FIG. 6;

[0024] FIGS. 9A-9B are perspective views of a portion of a bioprosthetic heart valve of the present application shown

closed and open, respectively, and FIG. 9C is an enlargement of one corner of a leaflet;

[0025] FIGS. 10A-10B are radial sectional views through a cusp region of the heart valve of FIGS. 9A and 9B showing an exemplary attachment between flexible leaflets and wireform;

[0026] FIG. 10C is a radial sectional view similar to FIG. 10B and illustrating the difference in flow orifice area between attaching the flexible leaflets underneath and over the wireform;

[0027] FIGS. 11A-11B are perspective views of a portion of an alternative dual-wireform bioprosthetic heart valve of the present application shown closed and open, respectively;

[0028] FIGS. 12A-12B are radial sectional views through a cusp region of the heart valve of FIGS. 11A and 11B showing an exemplary attachment between flexible leaflets and the dual wireforms;

[0029] FIG. 12C is a radial sectional view similar to FIG. 12B and illustrating the difference in flow orifice area between attaching the flexible leaflets underneath and over an inner wireform;

[0030] FIG. 13 is a perspective view of an assembled heart valve as in FIGS. 11A and 11B with dual wireforms which cross over each other at the commissure regions;

[0031] FIG. 14 is a perspective view of a still further prosthetic heart valve of the present application having a single wireform and clips at the commissure regions;

[0032] FIG. 15 is a perspective view of a dual-wireform prosthetic heart valve;

[0033] FIG. 16 illustrates one step in a procedure for assembling the dual-wireform prosthetic heart valve of FIG. 15;

[0034] FIGS. 17A-17C are radial sectional views through cusps of a dual-wireform prosthetic heart valve of the present application;

[0035] FIGS. 18A and 18B illustrate two different implantation configurations for the dual-wireform prosthetic heart valves disclosed herein;

[0036] FIGS. 19A and 19B are exploded and assembled views of two wireforms in an alternative dual-wireform prosthetic heart valve having a truncated lower wireform; and

[0037] FIGS. 20A and 20B are detailed views of a commissure post region of an assembled heart valve of FIGS. 19A and 19B showing one way to attach flexible leaflets to an upper wireform.

DETAILED DESCRIPTION OF THE PREFERRED EMBODIMENTS

[0038] The present application describes certain principles that may be used in conjunction or separately for fabricating flexible leaflet prosthetic heart valves to reduce the pressure gradient of blood through the valve orifice. As general statements of benefits obtained from such a valve: the valve should open properly upon forward flow with minimal gradient; the valve should close properly and completely upon reverse flow with little regurgitation; the support structure (e.g., wireform) of the valve should be able to withstand the fatigue stress during a large number of the valve open/close cycles and maintain structural integrity; and the flexible leaflets should withstand the structural stress and maintain the structural function of opening and closing without calcification or structural deterioration.

**[0039]** The desire for these attributes is not necessarily new in the field of prosthetic heart valve design, but valves constructed based on the principles described herein improve on each, in particular by increasing the effective flow orifice area through the valve for a given size. It should be understood that the characteristics of heart valves expressed herein may be implemented in a variety of different flexible leaflet valves. For example, though three- or tri-leaflet valves are the most common and most studied, only two or a greater number of leaflets may also be used. Also, the support frame, or structural skeleton, for the flexible leaflets may take a variety of forms in addition to those illustrated and described herein. The valve support frame may be relatively dimensionally stable, or configured to be collapsible for minimally-invasive delivery. Finally, materials and fabrication techniques may vary while still conforming any valve to the described desirable principles. In summary, the present application encompasses many valves that include one or more of these variable aspects, only limited by the appended claims.

**[0040]** As used herein, a “neutral position” or a “neutral configuration” means a configuration of a valve and/or a frame when the respective valve and/or frame is at-rest (e.g., still) and free from externally applied loads (e.g., pressure gradients through the valve, forces applied by retaining and/or delivery devices to retain the valve in a collapsed configuration), and is not biased toward any other shape.

**[0041]** Further, the term “wireform” refers to an elongated rod-like structure formed into a continuous shape defining a circumference around a flow orifice for supporting flexible leaflets in the various prosthetic valves herein. Typically a wireform has an undulating shape with alternating inflow cusps and outflow commissures; usually three each. The wireforms described herein may be machined from tubes or wires, or may be molded if made of a polymer. The continuous structure may be homogenous with no joints, or a crimp may be used to join two ends of a preformed wire. The cross-section may be round, oval, square or other suitable configuration.

**[0042]** A prosthetic heart valve **20** of the prior art shown in FIGS. 1-5 includes an inlet end **22** and an outlet end **24** (FIG. 3) separated along a generally vertical flow axis **26** through approximately the middle of the valve. (It should be noted that blood flow through a heart valve is not precisely like flow through a tubular pipe, and thus the term “flow axis” should be understood to be an approximation and refers generally to an axis through the center of the valve orifice.) A cloth-covered support frame includes an annular stent assembly **28** and an annular wireform **30**. The support frame defines a periphery and flow orifice of the valve. Both the stent assembly **28** and wireform **30** include commissure posts that project generally axially in the outflow direction and combine to form commissures **32** of the valve when covered with fabric. Both stent assembly **28** and wireform **30** also include arcuate cusps that curve in the inflow direction in between each two commissures that combine to form valve cusps **34**. In the illustrated embodiment, the stent assembly **28** includes two annular bands, an outer metallic band and an inner polyester band that extends up the commissures. Three flexible leaflets **36** couple to the support frame and extend inward therefrom. The leaflets **36** attach along an undulating line that follows the commissures **32** and cusps **34**. A suture-permeable sewing ring **38** surrounds the inflow end of the valve **20** and, as shown, features a

non-planar peripheral shape which undulates upward a short distance in the vicinity of the three commissures **32**. A planar sewing ring **38** may also be used.

**[0043]** The leaflets **36** may be provided by a whole porcine valve, but are preferably formed individually from bioprosthetic material such as bovine pericardium. It should be noted that a number of advantages of the present application are independent of the type of flexible leaflet, though the maximum benefit will be obtained by using sheets of bovine pericardium trimmed to particular sizes and shapes, as will be explained. Although not presently used in commercial valves, synthetic material may also be used for the leaflets, and the term, “flexible leaflets” is meant to include such other materials.

**[0044]** The prosthetic heart valves illustrated in FIGS. 1-5 represents the construction of a Carpentier-Edwards mitral pericardial valve, one of the leading commercially available bioprosthetic valves, available from Edwards Lifesciences of Irvine, Calif. The assembly process for the Carpentier-Edwards valve includes sewing the pericardial leaflets **36** to a cloth-covered wireform **30**, and then this subassembly is mounted to a cloth-covered stent assembly **28** having a silicone sewing ring **38** connected thereto with sutures. The cloth covering of each component and their subsequent assembly is elaborate and labor-intensive.

**[0045]** However, this particular valve construction has a proven track record, partly because of the highly durable configuration where the valve leaflets **36** connect to the valve commissures **32**. With reference to the enlarged view in FIG. 5, the leaflets **36** extend underneath the wireform **30** and outward through adjacent wires at the commissures **32**, and are sandwiched between the wireform and a cloth tab (not shown) provide on the stent assembly **28**. Commissure tabs **40** of adjacent leaflets **36** project through the commissure regions of the wireform **30** and wrap around the commissure posts of the stent assembly **28**. By wrapping the leaflet tabs **40** in this manner, and securing them on the exterior of the stent assembly **28**, the relatively high inward forces imparted to the free edges of the leaflets **36** from when the leaflets close are distributed to the stent assembly **28** and wireform **30**, not just to sutures connecting the leaflets to the surrounding structure.

**[0046]** FIG. 1A shows the bioprosthetic heart valve **20** with the leaflets **36** closed. In use, the leaflets **36** open or separate from blood flow from the inflow end **22** to the outflow end **24**, or in the outflow direction. Typical valves of the prior art have relatively floppy leaflets **36** that generally effectively coapt or meet in the flow orifice during the back flow portion of the flow cycle, as in FIGS. 1-3. The commissures **32** usually tilt somewhat inwardly relative to the central flow axis **26** from their inflow to their outflow ends so as to define a surface of revolution that surrounds a converging conical volume. This arrangement provides a flow constriction wherein the size of the orifice provided by the commissure posts **32** and leaflets **36** in the valve open state is smaller than the generally circular orifice defined at the inflow end **22**. The combination of the generally conical flow column and typical valve assembly introduces flow restrictions that increase the fluid pressure gradient through the valve as opposed to a smooth cylinder, or idealized pipe flow.

**[0047]** FIGS. 6-8 illustrate construction of another commercially-available bioprosthetic heart valve **50**, the Tri-fecta™ aortic valve available from St. Jude Medical of St.

Paul, Minn. The valve **50** includes an inner polymer stent **52** having three generally axially-aligned commissure posts **54**, and a sewing ring **56** surrounding the inflow end of the stent. A single sheet of bioprosthetic tissue **58** wraps around the outside of the stent **52** and is sewn thereto with sutures **60** along its commissure posts **54**, and also along a peripheral line adjacent the sewing ring **56**. The bioprosthetic tissue **58** is slightly taller than the stent commissure posts **54** to help provide enough free leaflet material ostensibly for good coaptation in the flow orifice. However, the extra leaflet material above the commissure posts **54** sometimes leads to leaflet prolapse, or poor coaptation and durability. Other so-called wrap-around designs of heart valves in the prior art include the Mitroflow valve from the Sorin Group of Milan, Italy, and the Ionescu-Shiley valve from Shiley Labs of Irvine, Calif.

**[0048]** The present application provides prosthetic heart valves that are constructed to have proven durability and to maximize effective orifice area. More particularly, the heart valves described herein have flexible leaflets that are connected to a wireform/stent structure much like the Edwards Lifesciences Carpentier-Edwards valves described above with respect to FIGS. 1-5. At the same time, the flexible leaflets are attached over the top of at least one part of the wireform to increase the orifice area. The wireform may be provided in one or two parts.

**[0049]** With reference now to FIG. 9A, a prosthetic heart valve **70** of the present application is represented by a single leaflet **72** (out of three) and its positional relationship to one third of a wireform **74**. The wireform **74** extends in an undulating pattern (alternating cusps and commissures) around the entire heart valve, as with wireforms of the prior art. The reader will understand that additional constructional details such as the stent assembly or sewing ring are not shown for clarity. The leaflet **72** includes a free edge **76** that coapts within the orifice defined by the valve with the other leaflets (not shown). The free edge **76** of the leaflet terminates at either end in tabs **78**. As with the Carpentier-Edwards heart valve described above, the leaflet tabs **78** extend outward underneath the inverted U-shaped commissures of the wireform **74** and preferably wrap around and are sewn to commissure posts of a stent structure (not shown). The leaflet **72** additionally has an arcuate cusp edge **80** that is secured around a cusp of the wireform **74**, but instead of extending underneath the wireform and being sandwiched against the underlying stent structure, the leaflet **72** extends over the top of the wireform cusp **74**, such as shown in FIG. 10A. Although not shown, the wireform **74** will again be cloth-covered, and the outer arcuate cusp edge **80** will be secured to an outer tab on the cloth covering with sutures, for example. In one embodiment, the outer cusp edge **80** wraps over and underneath the wireform **74** during assembly.

**[0050]** To enable this over-under attachment of the leaflet **72**, a gap or slot **86** is provided between each leaflet tab **78** and the adjacent portion of the outer cusp edge **80**. The slot **86** has a width that is approximately equal to the diameter of the wireform **74**, and extends generally radially inward from the curved outer cusp edge **80** of the leaflet. To help prevent blood leakage in the area near the slot **86**, additional fabric can be sewn around that area to secure the leaflet **72** as well as close any holes that might leak. An alternative to the slot **86** is a small hole in the leaflet **72** having a diameter approximately equal to the diameter of the wireform **74**. In this embodiment, the “gap” between the tabs **78** and the cusp

edge **80** can be a slit cut in the leaflet (i.e., the gap width is zero) from its cusp edge to the small hole. Alternatively, the slot **86** may be located within the tab **78** which helps facilitate attachment and conceal any opening that might leak.

**[0051]** In one embodiment, the slot **86** is reinforced to help prevent tearing. For example, FIG. 9C shows an enlargement of one corner of the leaflet where the area around the slot has a reinforced strip **87**. The strip **87** may be an added layer of bioprosthetic tissue, or a section of fabric such as Dacron. Alternatively, the slot **86** may terminate in a rounded hole to closely conform around the wireform **74** and reduce points of high stress, as well as having the reinforced strip **87**. Another possibility is to leave the portion of the leaflet **72** around the slot **86** much thicker than the rest of the leaflet, such as by cutting the leaflet from particular areas of the pericardial sac, or by thinning the rest of the leaflet.

**[0052]** It should also be noted that the length of the leaflet free edge **76** between the tabs **78** is designed to encourage full opening of the leaflet. If  $R$  is the wireform radius at the location of its commissures, then the length of the leaflet free edge **76** is equal to at least about  $2 \square R/3$ .

**[0053]** FIG. 9A illustrates the leaflet **72** in its closed position, with the free edge **76** bowed inward so that its midpoint lies essentially along a central flow axis through the valve and coapts with the other two leaflets. FIG. 10A shows the leaflet **72** extending inward over the wireform **74**. Conversely, FIG. 9B shows the leaflet **72** in its open configuration with blood flow **82** indicated by upward arrows through the flow orifice. As can be seen in FIG. 10B, positioning the outer edge of the leaflet **72** over the top of the wireform **74** maximizes the effective orifice area by eliminating any impediment to flow caused by the leaflet **72** projecting inward from the wireform **74**. FIG. 10C illustrates a leaflet **84** of the prior art attached underneath the wireform **74**, and also shows the new arrangement with the leaflet **72** attached over the wireform. The region in between the two leaflets **72**, **84** indicates the area in which flow may be restricted by the “under-the-wireform” leaflet.

**[0054]** In addition to a single-wire wireform such as shown at **74** above, the present application also contemplates a “sandwiched” configuration of a dual-wire wireform, such as shown in FIGS. 11-12. More particularly, a prosthetic heart valve **90** is again represented by a single leaflet **92** shown in its orientation relative to a wireform assembly of an outer wireform **94** and an inner wireform **96**. Again, both of the wireforms **94**, **96** extend around the periphery of the heart valve in an undulating pattern with cusps and commissures.

**[0055]** The overall profile of the inner wireform **96** is smaller in radius and shorter in axial dimension than the outer wireform **94**. However, at the commissure regions, the inner wireform **96** bends outward so that it is radially outside the outer wireform **94** to serve as the sewing anchor for the leaflet tabs **98**. That is, the commissures of the inner wireform **96** take the place of the commissure posts of a stent structure, as in the prior art. Adjacent leaflet tabs **98** wrap around the inner wireform **96** and are sewn together. The OD of the inner wireform **96** at the cusp region should be equal to the size of the valve. That is, each valve has an identified size, typically in odd 2 mm increments from 19-29 mm. The inner wireform **96** thus has a diameter at its cusps that is about 19 mm for a size **19** valve, and so on. The inner

wireform **96** thus helps to maintain a leaflet opening area as large as the circular opening area of the inner wireform.

**[0056]** The outer wireform **94** follows a similar contour profile as existing wireforms of the prior art, though it has a larger diameter. The leaflet **92** is sandwiched between the two wireforms **94, 96** in the belly area. The leaflets **92** wrap over the inner wireform **96** and then under the outer wireform **94** which keeps the leaflet belly in place. The gap between the inner and outer wireforms **94, 96** in the belly region (center of the cusps) is therefore approximately equal to the thickness of the leaflet **92**. In the commissure region, the leaflet tabs **98** pass under the inverted U-shaped commissures of the outer wireform **94**, which thus keeps the leaflet tabs together so that the three leaflets maintain the coaptation when closed. The leaflet belly edges can be inserted underneath the outer wireform and then typically sewn together with a sewing ring (not shown). Although a sewing ring is used in conventional heart valves, some newer configurations eliminate it for various reasons. For example, some heart valves attach to the annulus through self-contained structure such as clamps, stents, or barbs, or are otherwise attached without (primarily) using sutures, which is the main purpose of a sewing ring. Also, a soft ring may be provided around the valve to seal against the surrounding annulus and prevent leakage around the valve, but it may not be a conventional sewing ring in that it is not used as the primary anchoring structure with sutures.

**[0057]** The two wireform assembly serves several purposes. The cusp region of the inner wireform **96** keeps the same contour profile and same circular opening diameter as the existing wireform from valves of the prior art. The inner wireform **96** thus helps to maintain a maximum opening profile since the leaflet rests on top of the inner wireform in the belly region. At the same time, the outer wireform **94** keeps the leaflet belly in place and maintains the leaflet tabs **98** together to enhance coaptation. Further, the inner wireform **96** bends outward at the commissures to provide the attachment structure for the leaflet tabs **98**, thus eliminating one purpose for the stent structure in prior art valves. Indeed, the entire valve may include the two wireforms **94, 96** covered with cloth and sewn to the leaflets **92**, plus a suture-permeable sewing ring **100** (See FIG. **12A**) secured around the periphery of the wireform assembly. Again, the sewing ring is shown here as an example only, and may represent a sealing ring or may be eliminated altogether.

**[0058]** FIG. **12A** illustrates an exemplary construction where the outer edge of the leaflet **92** is wrapped around the outer wireform **94** and the sewing ring **100** is secured there around. Each of the wireforms **94, 96** will be covered with fabric, although that has been omitted for clarity. The fabric around the wireforms **94, 96** may be sewn to the sewing ring **100**, which typically includes an inner silicone core **102** surrounded by fabric **104**. FIG. **12A** shows the valve and its closed position with the leaflet **92** caused by fluid backflow to move to the middle of the flow orifice and coapt against the other leaflets.

**[0059]** On the other hand, FIGS. **11B** and **12B** show the leaflet in an open configuration, with blood flow **106** indicated. Because the leaflet **92** extends over the top of the inner wireform **96**, it does not present an impediment to blood flow and thus maximizes the effective orifice area. FIG. **12C** again illustrates the position of a leaflet **108** that is attached underneath the inner wireform **96** in the open configuration of the valve. The region **110** in-between this leaflet **108** and

a leaflet **92** that extend over the wireform **96** is the difference in orifice flow area which is gained by use of the present valve constructions.

**[0060]** FIG. **13** is a perspective view of an assembled heart valve as in FIGS. **11A** and **11B** with the dual wireforms **94, 96** which cross over each other at the commissure regions. The outer wireform **94** is always observable, and the inner wireform **96** is covered by the leaflets except at commissure tips which bend to the outside of the outer wireform. The tabs of the leaflets **92** are sandwiched between the outer wireform **94** and inner wireform **96** at the commissural posts. In a preferred embodiment, the tabs of the leaflets **92** wrap around the inner wireform **96**, which is not shown because the entire assembly is covered with fabric.

**[0061]** Another alternative prosthetic heart valve **120** is seen in FIG. **14**. As with the first environment, there is a single-wire wireform **122** over which the cusp edges of each leaflet **124** attaches. Leaflet tabs **126** wrap around stent commissure posts **128** which are bent outward and then generally axially again to make room for a commissural clip **130**. The clips **130** help maintain good leaflet coaptation while reducing stresses in the leaflet for better durability. Once again, because each leaflet **124** extends over the top of the wireform **122**, the effective orifice area is maximized. Although not shown, cloth coverings around the wireform **122** and the clips **130** are sewn together to secure the assembly. The clips **130** are shown as closed ovals, though other configurations are possible.

**[0062]** FIG. **15** is a subassembly of a dual-wireform prosthetic heart valve **140** with the leaflets **142** secured therein. An outer cloth-covered wireform **144** attaches under an inner cloth-covered wireform **146**. Although not shown, a sewing ring may attach around the cusp portions of the wireforms **144, 146**, with the gaps at the commissure portions of the wireforms filled-in with fabric or other such material to prevent leakage.

**[0063]** The dual-wireform valve **140** of FIG. **15** may be assembled as seen in FIG. **16**. More particularly, the outer or larger cloth-covered wireform **144** attaches underneath or around the inner cloth-covered wireform **146**. Preferably, the flexible leaflets **142** are pre-attached to the inner wireform **146** as shown. The outer wireform **144** may align directly below the inner wireform **146**, or may be slightly radially larger.

**[0064]** As seen in FIGS. **17A-17C**, the wireforms **144, 146** may be round or square in cross-section, or have another polygonal shape. Wireforms with square or rectangular cross-sections may lock together or stay axially aligned better than wireforms with round cross-sections. It should be noted that the wire diameters of both the inner and outer wireforms **144, 146** can be the same or different so as to change the spring rate, commissure deflection rate, and valve function.

**[0065]** In a preferred embodiment, the wireforms for any of the valves disclosed herein are a cobalt-chromium-nickel alloy such as Elgiloy. However, the wireforms can be formed of any semi-rigid (meaning not floppy) metallic or polymeric materials that possess sufficient elasticity to maintain their shape for delivery and implant yet are capable of flexing to a small degree post-implant from natural systolic-diastolic forces. Elgiloy, stainless steel, titanium, and Nitinol are all possible metallic materials, and various polyester or nylon synthetic materials are options.

[0066] As seen in FIGS. 17A-17C, a cloth tab 150 attached to the outer wireform 144 extends beyond a cloth tab 152 attached to the inner wireform 146. A small piece of silicone tubing or ribbon 154 may be added to the larger cloth tab 150 at least at the cusps of the wireform 144 to provide a sewing ring or sorts and larger target for needle penetration. The leaflets 142 are sandwiched between the two wireforms 144, 146, and are sewn thereto through the adjacent cloth tabs 150, 152. It should be noted that the cross-sectional shapes of the wireforms 144, 146 are shown in a variety of ways to emphasize possible combinations; both rounded, one square and one rounded, etc.

[0067] In an exemplary implementation procedure, the valve 140 would directly attach to the wall of the aorta using the larger cloth tab 150 of the outer wireform 144. The tab 150 can be bent downward as in FIG. 18A, or upward as in FIG. 18B. The cloth tab 150 extends up and down the wireforms 144, 146, and thus follows the natural scalloped shape of the aortic wall. Although not shown, the attachment of the leaflets 142 at the commissures may be configured the same as any of the other dual-wireform valves disclosed herein, such as by bending the inner wireform 146 radially outward and wrapping leaflet tabs around it.

[0068] The highly flexible valve provided by the dual wireform assembly of FIGS. 15-18 greatly improves hemodynamics over aortic valves currently on the market having relatively rigid annular frames. The attachment up and down the commissures at the aorta maximizes the size of valve which can be implanted. It is also anticipated that this valve will have similar durability properties compared to those currently produced since the leaflets are supported from above and below by wireforms. Moreover, the valve 140 also realizes significant cost savings over currently manufactured valves. The relatively simple assembly of the dual wireforms as seen in FIG. 16 replaces the labor-intensive stitching typically required with numerous cloth-covered components.

[0069] Moreover, the dual-wireform valve 140 of FIG. 15 eliminates any rigid annular components of the heart valve, which is a fairly standard construction in commercial valves. Consequently, the three cusp portions of the wireforms 144, 146 are relatively free to expand and contract with the surrounding annulus and ascending aorta, thus improving hemodynamics. Furthermore, the highly flexible nature of the dual-wireform valve 140 facilitates a subsequent valve-in-valve procedure. Over time, prosthetic heart valves may experience reduced performance from calcification, for example, requiring replacement. One technique available is to implant an expandable valve directly inside the existing prosthetic valve. However, prior surgical valves typically have rigid annular internal frames or stents, so that the second valve cannot be expanded to the same orifice diameter. With the highly flexible dual-wireform valve 140, however, a subsequently implanted valve can be balloon expanded and force the first valve open. The cusp regions separate from the outward force, and the new valve will then expand to a suitable diameter without sacrificing any flow volume from the valve-in-valve procedure.

[0070] FIGS. 19A and 19B show upper and lower wireforms 160, 162 for use in an alternative dual-wireform prosthetic heart valve. The upper wireform 160 has substantially the same configuration as those described above, with alternating arcuate cusps 164 and inverted U-shaped commissures 166. The lower wireform 162 on the other hand is

truncated with three arcuate valleys 170 that match the shape of the upper wireform cusps 164 and three upstanding peaks 172 that extend only partway up the upper wireform commissures 166. In one embodiment, the height of the lower wireform 162 at the peaks 172 is about one half the height of the upper wireform 160 at the commissures 166. The assembled wireform structure seen in FIG. 19B shows the upper wireform commissures 166 generally unsupported by the lower wireform 162. Flexible leaflets 180 are supported by the combination of the upper and lower wireforms 160, 162, and are shown schematically without connecting structure merely to indicate their placement. As will be explained, both the upper and lower wireforms 160, 162 are typically covered with fabric to facilitate their attachment to each other and to the leaflets 180 using sutures or the like.

[0071] In a similar manner as the version of FIG. 15, a sewing ring (not shown) may attach around the cusp portions of the wireforms 160, 162, with gaps at the commissures regions filled-in with fabric or other such material to prevent leakage. For instance, a sewing ring such as the cloth tab 150 seen in FIG. 18A and 18B may be used. Peripheral edges of the flexible leaflets 180 are desirably sandwiched between the two wireforms 160, 162 at least in the cusp regions, much like was described above with respect to FIGS. 17A-17C.

[0072] FIGS. 20A and 20B show a commissure post region of an assembled heart valve illustrating a manner of attaching the flexible leaflets 180 to the upper wireform commissures 166. In particular, a cloth (polyester fabric) covering 182 that extends along the length of the upper wireform 160 includes tab extensions 184 at the upper regions of the commissures 166 to which leaflet tabs 186 are sewn. The leaflet tabs 186 project radially outward between the spaced wires of the commissures 166 and between the cloth tab extensions 184. FIG. 20A shows a partial assembly to make clear the connection, and the combined tab of the cloth tab extensions 184 and leaflet tabs 186 are preferably rolled or folded and sewn with sutures 188 into a bundle 190 outside of the commissures 166 as seen in FIG. 20B. This bundle 190 is larger than the gap between the spaced wires of the commissures 166, and thus the leaflet tabs 186 are secured to the commissures 166 and have little stress imparted to the connecting sutures 188 because of the bundled configuration. Optionally, a small insert (not shown) of stiffer cloth or polymer may be rolled up within the bundle 190 for additional bulk to maintain the bundle on the outside of the commissures 166.

[0073] While the invention has been described in its preferred embodiments, it is to be understood that the words which have been used are words of description and not of limitation. Therefore, changes may be made within the appended claims without departing from the true scope of the invention.

What is claimed is:

1. A prosthetic heart valve, comprising:
  - a first cloth-covered undulating rod-like wireform having alternating cusps and commissures around a periphery;
  - a second cloth-covered undulating rod-like wireform having alternating cusps and commissures around a periphery, the cusps and commissures of the first and second wireforms being circumferentially aligned with one another; and

- a plurality of flexible leaflets having outer edges sandwiched between the cusps of the first and second cloth-covered undulating wireforms.
- 2. The heart valve of claim 1, wherein a cloth tab on one of the wireforms encompasses a small piece of silicone ribbon at least at the cusps thereof to provide a sewing ring.
- 3. The heart valve of claim 1, wherein the flexible leaflets have commissure edges sandwiched between the commissures of the first and second cloth-covered undulating wireforms.
- 4. The heart valve of claim 1, wherein cusps of both the first and second wireforms curve in an inflow direction and the commissures of both the first and second wireforms define upstanding commissure posts with inverted U-shapes projecting in an outflow direction.
- 5. The heart valve of claim 4, wherein the first wireform is slightly smaller in radius and shorter in axial dimension than the second wireform which is positioned outward from the first wireform except at the aligned commissures where the first wireform bends outward so that its commissures are radially outside the second wireform and provide sewing anchors for commissure tabs of the flexible leaflets.
- 6. The heart valve of claim 5, wherein the flexible leaflets each have tabs that are sandwiched between the first and second wireforms at the aligned commissures.
- 7. The heart valve of claim 6, wherein the tabs of the flexible leaflets wrap around the first wireform and are attached thereto at the aligned commissures.
- 8. The heart valve of claim 4, wherein the commissures of the first wireform are shorter in height than the commissures of the second wireform.
- 9. The heart valve of claim 8, wherein the first wireform has truncated commissures of about one half the height of the commissures of the second wireform.
- 10. The heart valve of claim 8, wherein the flexible leaflets have commissure tabs that extend outward through the inverted U-shaped commissures of the second cloth-covered wireform and are secured to cloth tabs extending from the cloth covering the second wireform.
- 11. A prosthetic heart valve, comprising:
  - a first undulating rod-like wireform having alternating cusps and commissures around a periphery;
  - a second undulating rod-like wireform having alternating cusps and commissures around a periphery, the cusps and commissures of the first and second wireforms being circumferentially aligned with one another

- wherein at least the cusps of the second wireform are stacked axially on top of the cusps of the first wireform; and
- a plurality of flexible leaflets having outer edges positioned and held between the cusps of the first and second undulating wireforms.
- 12. The heart valve of claim 11, wherein the first and second wireforms are cloth-covered, and a cloth tab on one of the wireforms encompasses a small piece of silicone ribbon at least at the cusps thereof to provide a sewing ring.
- 13. The heart valve of claim 11, wherein the first and second wireforms are cloth-covered, and the flexible leaflets have commissure edges sandwiched between the commissures of the first and second cloth-covered undulating wireforms.
- 14. The heart valve of claim 11, wherein cusps of both the first and second wireforms curve in an inflow direction and the commissures of both the first and second wireforms define upstanding commissure posts with inverted U-shapes projecting in an outflow direction.
- 15. The heart valve of claim 14, wherein the first wireform is slightly smaller in radius and shorter in axial dimension than the second wireform which is positioned outward from the first wireform except at the aligned commissures where the first wireform bends outward so that its commissures are radially outside the second wireform and provide sewing anchors for commissure tabs of the flexible leaflets.
- 16. The heart valve of claim 15, wherein the flexible leaflets each have tabs that are sandwiched between the first and second wireforms at the aligned commissures.
- 17. The heart valve of claim 16, wherein the tabs of the flexible leaflets wrap around the first wireform and are attached thereto at the aligned commissures.
- 18. The heart valve of claim 14, wherein the commissures of the first wireform are shorter in height than the commissures of the second wireform.
- 19. The heart valve of claim 18, wherein the first wireform has truncated commissures of about one half the height of the commissures of the second wireform.
- 20. The heart valve of claim 18, wherein the flexible leaflets have commissure tabs that extend outward through the inverted U-shaped commissures of the second wireform and are secured to cloth tabs extending from a cloth covering the second wireform.

\* \* \* \* \*